

# HYDRUS

2300

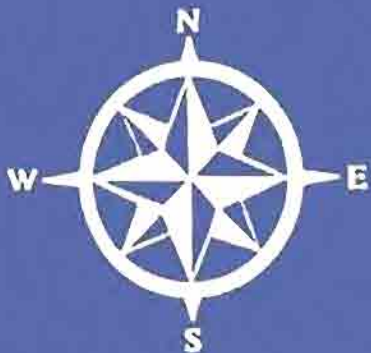



## **System Controls Description**

The main control panel is normally located at the pivot point and controls all of the operations of the pivot. The main panel controls the direction the pivot will operate, the speed of which the pivot will travel, automatically stop or reverse if equipped with proper options, and controls other optional functions that can be incorporated. The main control panel also monitors alignment of the pivot, any other safety conditions allowed, and will shut the system down if needed.

The intermediate tower panels perform the function of controlling each individual tower motor to keep the system in a straight line and also provide the safety functions to shut the system down if that alignment varies too far from the straight line configuration.

The stall tower provides the same operations as the standard intermediate tower, in addition, performs an over watering safety feature. The stall tower is generally located next to the end tower. If the stall (next- to- last) tower fails to receive a signal to move in a present amount of time, the system will shutdown and prevent over watering if the pump shutdown is operational.

The end tower sets the speed the pivot will travel around the field. The end tower is often referred to as the control tower and responds to a 120 volt A.C. signal sent out by the percentage timer in the main control panel. This signal sets the amount of time the end tower will be on and off during each one minute cycle, thereby controlling the speed the end tower will travel along the end tower track. This sets the amount of water applied to the crop, each tower between the end tower and the pivot line up, and between the two.



## 2300 Descriptions and Definitions

### Main Panel Inner Door

<u>Item</u>	<u>Description</u>
Main Disconnect Switch, Fused	<p>Controls the application of the three phase power to the system. The fuses provide short circuit and overload protection.</p> <p><b><u>DANGER!</u></b> When the main disconnect is in the “ON” position, the power is present. Do not open any box or perform any service work on the system where the main disconnect is on. Electrical shock may occur!</p>
Voltmeter	<p>Indicates the voltage supplied to the system and should indicate 480 volts when the disconnect switch is in the “ON” position.</p> <p><b><u>CAUTION!</u></b> Do not operate the system if meter reads above 510 volts or below 440 volts. Attempting to operate the system outside these limits could cause damage to electrical components.</p>
Hours Run Time	<p>Records the total number of hours the system has been operated. The hour meter operates only when the safety circuit is energized and the system is running.</p>
Speed Control (Percentage Timer)	<p>Controls the running time of the end tower drive unit which determines the overall rotation time of the pivot. The timer operates on a one minute cycle, i.e. at a 50% setting, the end tower will be on for 30 seconds and then off for 30 seconds.</p>



## **2300 Descriptions and Definitions**

End Tower on Light	Indicates that the percentage timer is generating a signal for the end tower to run. Operates only when the safety control circuit is energized and locked in or being bypassed by holding the start toggle switch in the "START" position.
System Control Switch (Start/ Override Switch)	<p>This is a momentary switch. When control power is available, pushing the switch up to the "START" position will attempt to start the system. If all safety circuits are closed, when released, the switch will return to the run position and the system will continue to operate. If any safety circuit is open, the system will shut down when the switch is released.</p> <p><b><u>CAUTION!</u></b> Holding the system control switch in the "START" position overrides all safety shutdown circuits including the alignment switches in the tower panels. Using this switch, if not carefully monitored, could cause structural damage to the system.</p>
Forward- Reverse Switch	This switch selects the direction that the system will travel in the field. Generally, forward is the clockwise direction when the pivot is viewed from above. Reverse is the counter-clockwise.
Pump Control Switch (Well Kill Switch)	This Circuit, if connected properly, automatically stops the pump when the system shuts down for any reason, thereby preventing over watering.



### **Main Panel Back Plate**

The components on the back plate consist primarily of the following:

1. Main Disconnect
2. Fuses: Branch Circuit, 500VAC, 30 amp, Type CC
3. Reversing Contactor with Mechanical Interlock
4. Control Transformer, .5KVA
5. Fuses: Transformer Primary, 500VAC, 3 amp, Type CC
6. Fuse: Transformer Secondary, 120VAC, 3 amp, Type FLQ
7. Relay, 120 VDC (12VDC Lockwood Optional)
8. Bridge rectifier, safety delay circuit
9. Terminal Blocks
10. Ground lug and Ground Blocks

**CAUTION!** It is important to the safety of the operator and maintenance personnel that all grounding is done properly. DO NOT connect incoming power wires to the main disconnect switch in the main panel until the entire system has been erected, fully wired and checked.

**NOTE:** HYDRUS Corporation strongly recommends the use of Lightning Arrestors. Provisions are made for mounting in the bottom of the main control panel. We also recommend that Lightning Arrestors be installed at the pump panel and the service entrance disconnect.

### **Intermediate Tower Panel**

The components in the intermediate tower panel consist primarily of the following:

1. Base and Cover
2. Terminal Block Assembly
3. Disconnect Switch
4. Motor Contactor
5. "Run" and "Safety" Micro switches
6. Cam and Shaft Assembly
7. Ground Bar

All incoming and outgoing span cables connect to the terminal block with the exception of the green or bare ground conductor and the small drain wire which is located under the metallic shield in the span cable. Both incoming and outgoing ground conductors and drain wires should be securely connected to the ground lug.

It is very important during the mounting of the tower panels to the machine that the ground wire (#10 green) with ring lug be attached to one of the mounting bolts that bonds to the machine. This is necessary to provide the grounding required by the National Electrical Code as well as validating Hydrus Corporation's warranty.



**CAUTION!** During initial installation or any maintenance and repair where the cover must be removed, the tower panel disconnect should be placed in the “OFF” position.

After replacement of the cover and before leaving the tower, it is important to remember to return the disconnect switch to the “ON” position, or the system will not operate without bypassing the safety and that tower will not move.

The spring mounted on the cam is not intended to take slack out of the linkage assembly. Its purpose is to provide a safety shut down in case of a linkage breakage. In this case, the spring drives the cam to open the safety Microswitch which shuts the system down.

### **Stall Tower Panel**

Stall tower panels are basically the same as Intermediate Tower Panels except an adjustable timer (0 up to 60 minutes) has been added.

The purpose of the timer in the stall tower is to shut down the center pivot and the pump after a period of inactivity of the end tower. Where the safety micro-switches monitor problems with any tower between the pivot and the end tower, the stall timer monitors the end tower. If the end tower fails to move far enough during the selected interval to call for the next to the end tower to move, the stall timer will cause a system to shutdown. Contacts on this timer break the safety return circuit upon the time down. The timer is reset by the run micro-switch signal to the tower contactor coil of the next to the end tower.

### **End Tower Panel**

The end tower is the speed control tower of the system as all the other towers line up between the pivot structure and the end tower. The end tower panel therefore does not contain the alignment components of the other towers. The Contactor coil of the end tower receives power from the control panel. The tower stops and starts with this signal.



## Options

### **Auto Restart Option**

Regardless of the manufacturer of the pivot, the **auto restart option** for the center pivot has the same basic function: to restart a system running when power returns after a failure or to be able to start a pivot by turning power on from a remote position.

Acting as if someone is engaging the start switch, the basic function of an auto restart option on a system is to momentarily close a contact. If all safety shutdowns are in the run status at that time, the system will continue to run. The auto restart needs a two second timing sequence to energize the “START” circuit for this function.

**CAUTION!** A system that is supplied by a well should not attempt to auto restart immediately after a power failure. If the power failure is only a momentary interruption and the power returns in a matter of seconds, the pump could be damaged by attempting to restart. When the pump stops, the column of water in the well casing starts downward creating too much load for the pump to start. An auto restart attempt should be an average of ten minutes after power returns to give the well time to settle down and the system time to drain preventing severe water hammer because of air and water pockets in the pipeline.

If the system has a low pressure shutdown option, a low pressure bypass has to be added with the auto restart. When the auto restart attempts to start the system, the system will shutdown after the attempted start because there is no water pressure after a power failure. The low pressure bypass will bypass the low pressure switch for an average of five minutes to allow time for the water pressure to build to the proper level for system operation. If after five minutes the water pressure has not reached the required level, the low pressure switch will shut the system down.

### **Auto Reverse Option**

The **Auto Reverse option** includes a pulsing relay for change of direction and delay timers for the “FOR/REV” main panel contactor assembly. The pulsing relay is controlled by the 120vac input from the Auto Reverse panel at the end of the pivot, through terminal block number 17 in the main control panel. The delay timers allow the “FOR/REV” contactor assembly to transition between Forward & Reverse by delaying the contactor coil voltage to change direction. When the “AUTO/MAN” switch on the panel is in the “AUTO” position, the option is active.



## **Electromechanical Start-Up Procedure**

**WARNING!** Be sure that the system has been properly grounded before any application of power.

**CAUTION!** Before starting the system, check the field for any obstructions such as vehicles, tractors, farm equipment, or any obstruction that may cause structural damage to the system, or items that may be damaged by the system.

### **Typical Start up Sequence for Commercial Power**

Before attempting to start the system, the operator should check the incoming voltage. Verify 480 VAC is available on all three phases with a voltmeter. If a voltmeter is not available, these are done simply by monitoring the panel voltmeter. The voltmeter is connected to L1 and L2. The control transformer is connected to L1 and L2. If the voltmeter reads 480 VAC you should have control power and be ready to start the pivot.

- Place the forward/ Reverse Switch in the desired position.
- Set the Speed Control (Percentage timer) to the desired speed.
- Place the Pump switch in the Start position, when the pivot is pressured up switch this over to the Run position.
- Place the Wet/Dry switch in the wet position if starting a pump and dry if not.
- Flip the System Control switch to the START position and release.
- After the system is running, place the Engine Pump switch to the Auto position.

### **Typical Start up Sequence for Engine Driven Generator**

- Verify disconnect switch in the pivot panel is in the OFF position.
- Place the Engine Pump switch in the START/DRY position.
- Make all safety checks of the engine fluids and shutdown systems.
- Start the engine.
- Engage pump clutch.

When water has reached the end of the system and all air has been discharged from the pipes, bring the engine speed up and set for and output voltage of 480 VAC.

**CAUTION!** Voltage in excess of 510 VAC may damage pivot panel, tower panels and motors.

Before attempting to start the system, the operator should check the incoming voltage. Verify 480 VAC is available on all three phases with a voltmeter. If a voltmeter is not available, this is done simply by monitoring the panel voltmeter and the Control Power Light. The voltmeter is connected to L1 and L2. The control transformer is connected to L1 and L2. If the voltmeter reads 480 VAC and the Control Power Light is on, this verifies power on all three legs.

- Turn the disconnect switch to the ON position.
- Place the Forward/Reverse Switch in the desired position.
- Set the Speed Control (Percentage Timer) to the desired speed, and then turn the Control Power switch to the ON position.
- Press the System Control switch to the START position, hold for 1second and release.





## **Troubleshooting Procedures**

**CAUTION!** Electrical troubleshooting should be only performed by a qualified electrician. This machine utilizes 480 volts AC power and may cause fatal shock if improperly handled.

### **Center pivot completely inoperable:**

**No three phase power;** Check for 480 volts at the top side of the main disconnect switch. If there is no power at the top side of the main disconnect switch, check the voltage at the power source. If the voltage exists at the power source, the fault is between the power source and the main disconnect switch.

**Main disconnect fuse(s) blown;** If voltage is present at the top of the main disconnect switch, check the voltage at the bottom of the main disconnect switch, with the main disconnect switch turned on. If the voltage is not present, the fault is with the fuses or the main disconnect switch. Turn off the main disconnect switch. It is recommended that the power source voltage be disconnected as well. Test for continuity of each fuse. If continuity exists, the fault is with the main disconnect switch.

**WARNING!** The main disconnect switch must be in the “OFF” position before attempting to remove any fuse. It is recommended that the power source voltage be disconnected as well. Use a proper fuse pulling tool to remove fuses. Failure to follow these safety precautions may cause fatal shock.

**3 amp fuse(s) blown;** If voltage is present at the bottom of the main disconnect switch, check for 480 volts between H1 and H2 on the control transformer. If no voltage is present, one or both of the 3 amp fuses are blown.

**Control transformer defective;** If 480 volts exists between H1 and H2 of the control transformer, check voltage between X1 and X2 of the control transformer. If the secondary voltage is less than 100 volts, replace the transformer.

**3 amp control fuse blown;** If there is a good voltage reading between X1 and X2 of the control transformer, with the control power toggle switch turned to the “ON” position, check for 120 volts AC on terminal block #1. If there is no voltage present on terminal #1, either the 3 amp control fuse is blown, or the control power toggle switch is defective. With the main disconnect in the “OFF” position, check for continuity of the three amp control fuse. If the three amp control fuse is blown, a fault may exist due to a short or overloading of control power circuit.

**System control switch defective;** If 120 volts AC exists on terminal #1 of the long terminal strip; with the system control toggle switch held in the “START” position, check for 120 volts AC on terminal #10. If voltage is not present on terminal #10 with the system control toggle switch held in the “START” position, the fault is either in the system control toggle switch or a bad connection.



**CAUTION!** Holding the system control switch in the “START” position overrides all safety shutdown circuits including the alignment switches in the tower panels. Using this switch, if not carefully monitored, could cause structural damage to the system.

### **Center pivot shuts down after system control switch is released from the “START” position:**

**Alignment shutdown:** With the system control switch in the “START” position, check the 120 VAC return to terminal 13. If no voltage is present, a tower could be out of alignment causing a safety Microswitch to open the safety circuit loop. If the tower can visually be identified, the cause for the tower shutdown must then be determined and corrected before realigning the system. When realigning the system, do not walk the system in the same direction that the alignment shutdown occurred. Change the direction so that the end tower moves in the direction to restore the system to a straight line.

**CAUTION!** If attempting to correct the system alignment error by walking the system in the same direction as the shutdown occurred, compression of the spans truss assemblies may occur and cause structural damage.

If a tower cannot be identified visually, it can be isolated by checking the safety circuit loop. To do this, remove the incoming wire from terminal 13 and insert into the ground bar. Go to the middle tower of the system and remove the safety wire from the safety Microswitch. Check for continuity to ground of each half of the safety loop. The open in the safety loop will be in the direction that does not show continuity to the ground. Reconnect the safety wire and continue the process of splitting the number of towers until the fault is isolated. Be sure to reconnect all wires to the proper positions after the test.

**Stall timer shutdown.** If the open in the safety loop does not appear in any of the safety microswitches, the fault could be in the stall timer located in the next to the end tower. This timer has a contact that opens when the next to the end tower fails to receive a signal to move in the time set on the timer. In the initial test of the above step, if there is no voltage present on terminal 13, change the direction of the system and attempt to start. This will reset the stall timer if it is functional, indicating that there is a problem with the end tower. To test the stall timer, recheck for continuity between terminal 3 & 4, 6 & 7 and 8 & 9 on the timer after removing the jumper wire from terminal 3 & 6. If this does not open, make sure that 120 VAC is being applied to terminal 1 of the timer. This could reset the timer. If this does not regain continuity between 3 & 4, 6 & 7 and 8 & 9, replace the timer.

**Optional kill functions shutdown.** If 120 VAC is present on terminal 13 in the initial test, check for 120 VAC on terminal 10. If not present, this would indicate a fault in any options installed between terminals 10 and 13.

**Safety delay circuit faults.** If voltage is present on terminal 10, check to see if the safety relay is energizing. If the relay does not move, check for 120 volts DC on terminals A and B of the relay socket. If 120 VDC is present, replace the relay. If 120 VDC is not present, replace the bridge rectifier.



End tower does not move:

**Reversing contactor not functioning:** With the system control switch in the “START” position, select “FORWARD” or “REVERSE” alternately, insuring that you can hear and see the mechanical operation of the contactors. If the contactors fail to operate correctly, measure for 120 VAC between terminals 8 and 2 in forward and terminals 9 and 2 in reverse. Absence of the voltage would indicate a defective forward-reverse switch. If the contactors are energizing, check the voltage between each phase on the outgoing wires, each phase should read approximately 460 to 480 VAC. If voltage is not present on any leg on the output side, and is present on the input side, replace the contactor.

**Percentage time defective:** With the percentage timer set to 100% and the system started, monitor the “End tower on” light. If the light is not on, check the voltage between terminals 4 and 2, it should be approximately 120 VAC. If the voltage is not present, check for bad connections or replace the percentage timer. If voltage is present, turn the percentage timer to 50% and make sure the voltage is intermittent.

**End tower circuit fault.** If voltage is present on terminal 4, leave system running and percentage timer set at 100%. Go to the end tower and check for 120 VAC on the contactor coil. If voltage is not present, check the wires in each tower panel by starting at the middle tower. If voltage is present on the end tower wire, check toward the end, if not, check toward the pivot.

**End tower contactor defective.** If the voltage is present on the contactor coil, check to see if the contactor is energizing. If not, turn the power off and check the coil of the end tower contactor. Remove at least one wire from the coil to insure a proper reading. The coil should ohm out at approximately **75 to 200 ohms**. If the coil has a high reading or is open, replace the contactor.

**End tower motor failure.** If the contactor is energizing, turn the power off and check end tower motor. The leads on the motor side of the contactor should read approximately **10 to 12 ohms** between each phase. Check all three phases. Check each leg to ground for continuity. There should be no continuity to ground. If either of these checks fails, check the motor leads again in the junction box on the side of the motor. If any leg shows continuity to ground, or any phase has a zero or high ohm reading, replace the motor.

**End tower drive train fault.** If the motor checks out good, check drive train gearboxes or couplings for any faults.



End tower runs continuously:

**Percentage timer fault;** With the percentage timer set at 50% and the outgoing wire disconnected, check the voltage on terminal 4. If the voltage is not intermittent and is present constantly, replace the percentage timer.

**End tower contactor fault.** If the voltage is intermittent on terminal 4, replace the outgoing wire and go to the end of the tower. Check the voltage on the contactor coil of the end tower panel. If the voltage is intermittent, check to see if the end tower contactor is stuck in the closed position.

**End tower circuit fault.** If the voltage is not intermittent and is constant on the contactor coil, check the end tower control circuit wires in each tower panel for a short circuit any wire that has 120 VAC present constantly such as the forward or reverse circuit of safety circuit.

Intermediate tower does not run:

**Alignment linkage is faulty or binding.** Check to make sure that the alignment linkage is working properly and activating the run Microswitch correctly. If the Microswitch is not being activated at all or at the incorrect position, repair and adjust the assembly as required.

**Forward/ reverse circuit faulty;** verify that the voltage is available by checking for 120 VAC between terminals 2 & 8 for forward and terminals 2 & 9 for reverse. If voltage is not present, check span cable or previous tower panel for fault.

**Tower run switch is defective.** If voltage is present, check to see if the tower contactor is energizing. If the contactor is not pulling in when the run Microswitch is operated, check for voltage on the contactor coil wire that is connected to "COMM" of the Microswitch. If the voltage is not present, check for loose connections. With the power turned OFF, check continuity on the run Microswitch while manually operating the switch. If you do not read continuity between "COMM" and "NC" while the switch is normal or between "COMM" and "NO" while the switch is depressed, replace the Microswitch.

**Contactor defective;** If voltage is present on the contactor coil wire that is connected to "COMM" of the run Microswitch, and the contactor is not pulling in, check the ohm reading of the coil and make sure that the contactor moves freely. The coil should ohm out at approximately 75 to 200 ohms. If the coil has a high reading or is open, replace the contactor.

**Motor has overheated or is defective.** With the system running, check for 480 volts between each phase on the incoming side of the contactor. If the voltage is present, turn the power OFF and ohm the leads to the motor. The leads on the motor side of the contactor should read approximately 10 to 12 ohms between each phase. Check all three phases. Check each leg to ground for continuity. There should be no continuity to ground. If either of these checks fails, check the motor leads again in the junction box on the side of the motor. If any leg shows continuity to ground, or any phase has a zero or high ohm reading, replace the motor.



**CAUTION!** This machine utilizes 480 volts AC power and may cause fatal shock if improperly handled. The main disconnect switch must be in the “OFF” position and locked to prevent accidental start up. Before attempting to check the 480 volt circuit for faults, it is recommended that the power source voltage be disconnected as well. Use the proper care when checking voltage on any live circuit. Failure to follow these safety precautions may cause a fatal shock.

**Intermediate tower runs continuously:**

**Alignment linkage faulty or binding;** Check to make sure that the alignment linkage is working properly and activating the run Microswitch correctly. If the Microswitch is not being activated at all or at the incorrect position, repair and adjust the assembly as required.

**Tower run switch is defective;** The run Microswitch may not be operating correctly to disconnect the voltage from the contactor coil when the switch is activated. With the power turned OFF, check the run Microswitch as indicated in the previous section and replace if needed.

**Contactor Fault;** If voltage is not present on the contactor coil, check to see if the contactor is stuck in the closed position. Replace if necessary.

**System will not reverse direction:**

**“FORWARD/ REVERSE” Switch faulty;** With the system control switch in the “START” position, select “FORWARD” and “REVERSE” alternately, insuring that you can hear and see mechanical operation of the contactors. If the contactors fail to operate correctly, measure for 120 VAC between terminals 8 and 2 in forward and terminals 9 and 2 in reverse. Absence of the voltage would indicate a defective “FORWARD/REVERSE” switch.

**Reversing contactor defective;** If voltage is present in the above checks, check for voltage on the contactor coils to insure proper connections. If voltage is present on the contactor coil and reversing contactors fails to operate, replace the reversing contactor.



Safety circuit fails to shut system down when system misalignment occurs:

**Faulty Safety microswitch;** The safety microswitch in each tower panel is wired on the normally closed contact to complete the safety loop when the system is functioning normally. The safety Microswitch circuit is always closed, unless the system moves out of alignment. These switches can be faulty and not be found until a safety condition occurs and the system does not shut down and causes some damage. As a safety precaution, it is advisable to test the safety microswitches in the system on a regular basis. Have an assistant start the system while you go to each tower and manually replace any faulty or suspect Microswitch found.

**Alignment linkage faulty or binding;** While at each tower, check for the proper operation of the linkage that controls the run and safety microswitches. Repair or adjust as necessary.

**Safety Circuit fault;** If there is a short between any other control wires with 120 VAC on the system, the safety loop from that point outward to the end tower is ineffective. This will be found during the safety check above. Correct any faults found before running system.

**Safety relay fault;** To see if the safety relay is operating correctly, disconnect the "Safety Relay" coil wires from the rectifier. If the relay contacts are welded in the closed position, the safety shutdown is ineffective. The above test would verify this also.

**Pivot Link Connection;** If using a pump control panel with a safety loop, connect your wires to terminal # 6 and terminal #7 when the safety is engaged on the pivot this loop will be closed. When going from Forward to reverse the capacitor offers a 4 second safety delay to keep the pump from shutting down, then having to restart.

**START/STOP Switch Faulty;** Check the "START/STOP" switch to make sure it is in the center or "Run" position. If the switch is in the up or "START" position, the safety circuit is bypassed. Replaced the switch if this occurs.



Products distributed by ICII are guaranteed only to the extent of the original manufacturer, which generally covers defects due to materials and workmanship on a replacement basis, F.O.B. factory.

- The warranty shall apply to and be limited to the original purchaser of any product manufactured by ICII. Any product found defective due to material, workmanship will be repaired or replaced at the option of ICII, free of charge, FOB the facility in Daphne, Alabama within a period of one (1) year from the date of delivery.
- Repairs of modifications by others than ICII or their authorized representatives shall render this Warranty null and void, unless approval is given in writing. For warranty claims; contact **ICII** at P.O. Box 945, Daphne, AL 36526. Provide identification or description of the product, the date of delivery, invoice number and the nature of the problem
- The Warranty provided above is the only Warranty made by ICII with respect to its products or any parts thereof and is made expressly in lieu of any other warranties, by course of dealing, usage of trade or otherwise expressed or implied, including but not limited to any implied warranties of fitness for any particular purpose or of merchantability under the uniform commercial code. It is agreed this Warranty is in lieu of and buyer hereby waives all other warranties, guarantees or liabilities arising by law or otherwise. Seller shall not incur any other obligations or liabilities or be liable to buyer, or any customer of buyer for any anticipated or lost profits, incidental or consequential damages, or any other losses or expenses incurred by reason of the purchase, installation, repair, use or misuse by buyer or third parties of its products (including any parts repaired or parts replaced); and seller does not authorize any person to assume for seller any other liability in connection with the products or parts thereof. This Warranty cannot be extended, altered or varied except by a written instrument signed by seller and buyer. ICII reserves the right to make improvements in design and material without prior notice to the trade.
- All sales and all agreement in relation to sales shall be deemed made at the manufacturers place of business in Daphne, Alabama and any dispute arising from any sale of agreement shall be interpreted under the laws of the State of Alabama, USA.

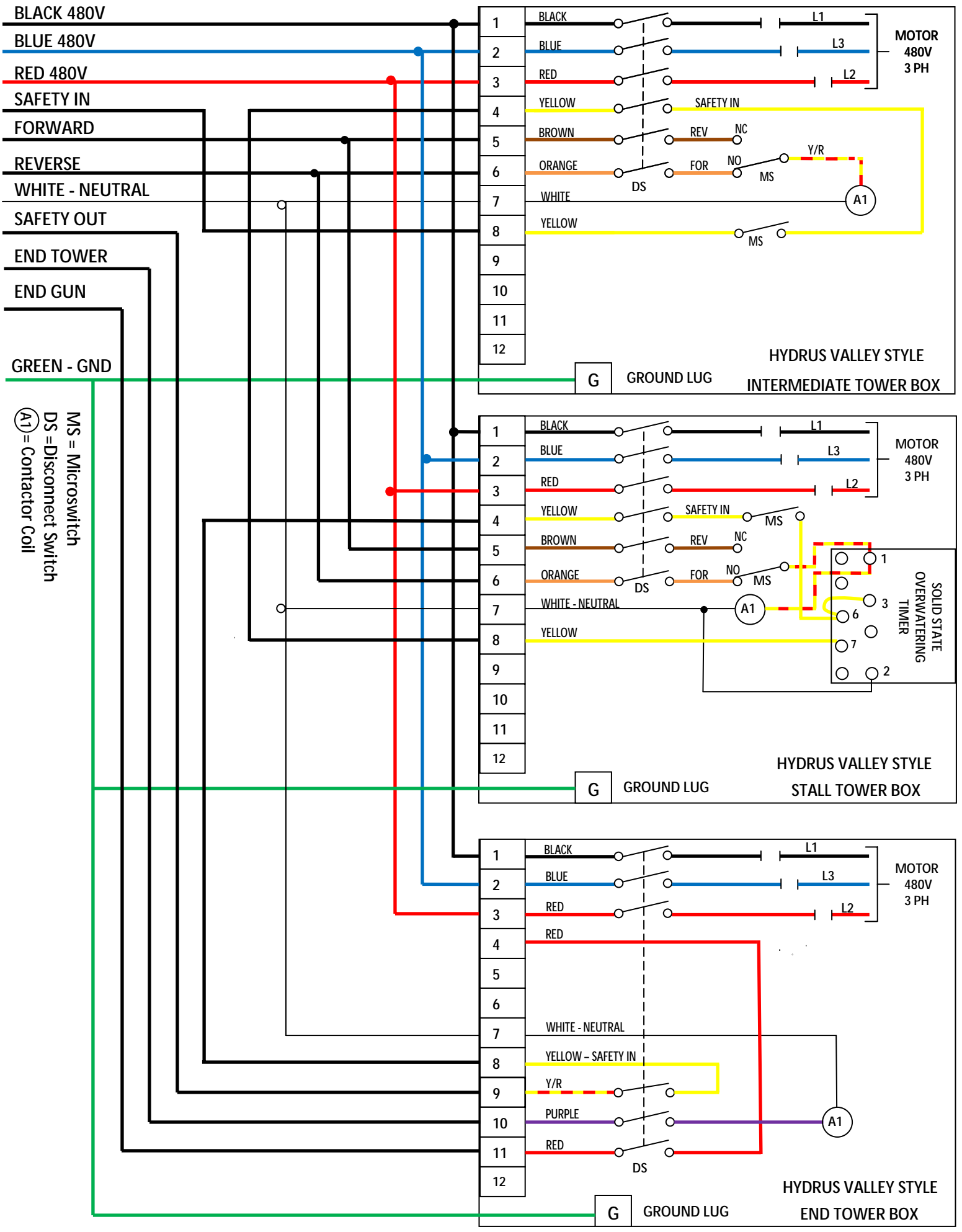



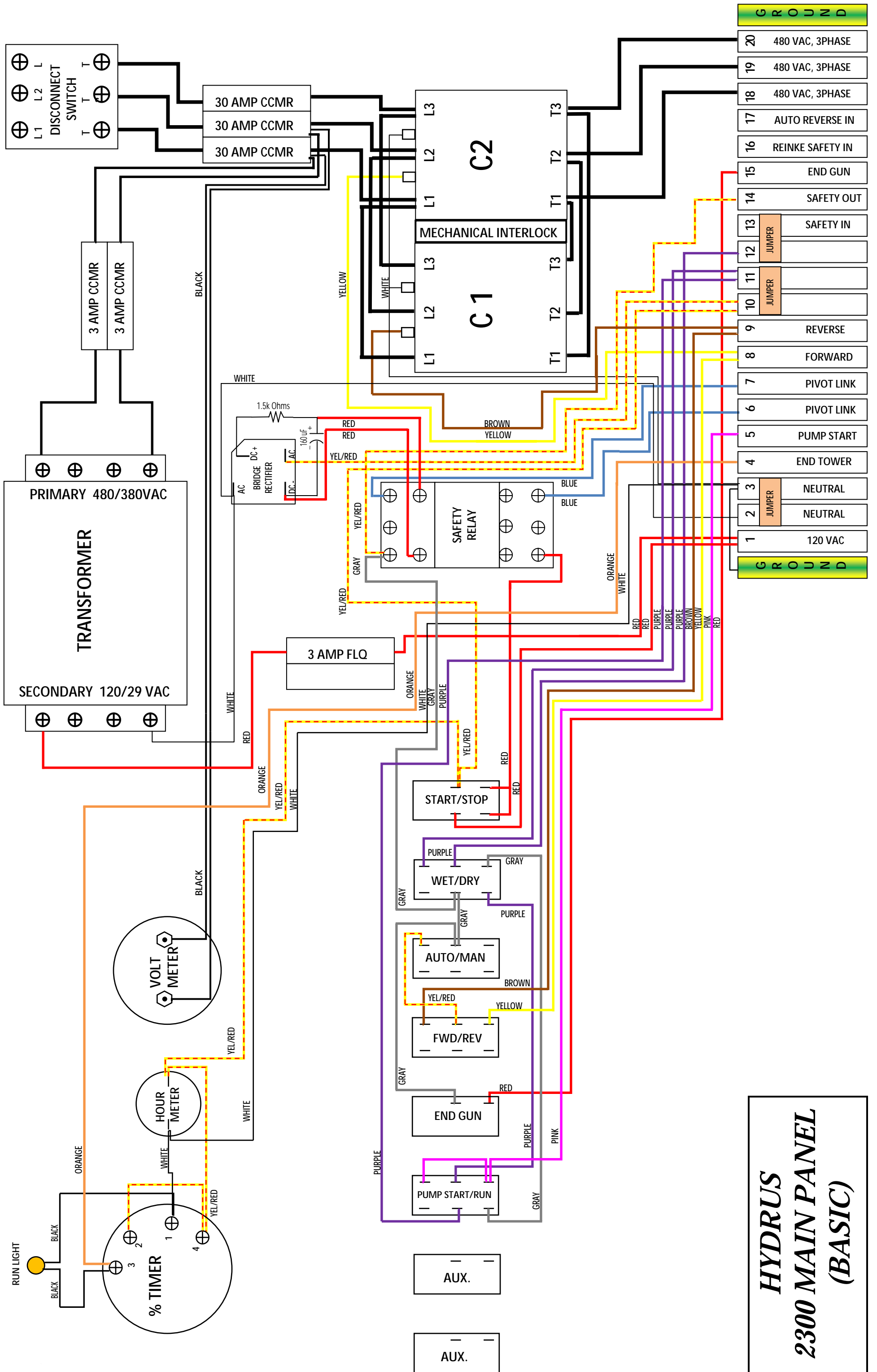

**HYDRUS  
2300 MAIN PANEL  
(BASIC)**

20	480 VAC, 3PHASE
19	480 VAC, 3PHASE
18	480 VAC, 3PHASE
17	AUTO REVERSE IN
16	REINKE SAFETY IN
15	END GUN
14	SAFETY OUT
13	SAFETY IN
12	JUMPER
11	JUMPER
10	JUMPER
9	REVERSE
8	FORWARD
7	PIVOT LINK
6	PIVOT LINK
5	PUMP START
4	END TOWER
3	NEUTRAL
2	JUMPER
1	NEUTRAL
1	120 VAC



Irrigation Components International (V.I.), Inc.

P.O. Box 945

Daphne, AL 36526 USA

Tel: 1.251.626.5470

Fax: 1.251.447.0190

Email: [icii@irricomp.com](mailto:icii@irricomp.com)